

**SERIAL NO. GF705766-DI**

**PRO FITNESS**

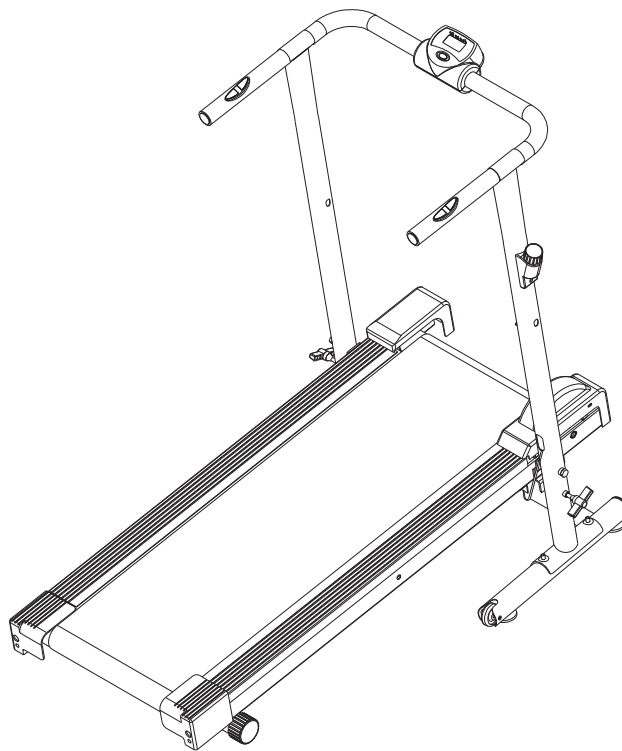

---

**Saturn Magnetic Folding Manual Treadmill**

---

*Assembly & User Manual*

**Please ensure that you read this manual carefully  
before attempting to assemble or use your new  
product and retain for future use**



# **Contents**

---

<i>Section</i>	<i>Page</i>
<b>General Information . . . . .</b>	<b>4</b>
<b>Before you start . . . . .</b>	<b>5</b>
<b>Safety . . . . .</b>	<b>6</b>
<b>Exercise Information . . . . .</b>	<b>7</b>
<b>Assembly . . . . .</b>	<b>12</b>



## General Information

---

### Quality

This exercise product has been designed and manufactured to comply with the latest (BS EN 957) British and European Safety Standards.

### Questions

Should you encounter any difficulty with the assembly, operation or use of your exercise product or if you think that you may have parts missing, please **DO NOT** return it to your retailer but contact **CUSTOMER SUPPORT**, by either of the following means.

### Customer Support

**Email:- [help@disupport.co.uk](mailto:help@disupport.co.uk)**

**Fax:- 01535 637722**

**Post: D.I. Support  
c/o Unit 8, Riparian Way,  
The Crossings, Cross Hills,  
West Yorkshire  
BD20 7BW**

### Queries

If you do have any queries, please ensure that you include the following information

YOUR NAME  
YOUR ADDRESS  
YOUR PHONE NUMBER  
PRODUCT MAKE OR BRAND  
PRODUCT MODEL  
PRODUCT SERIAL NUMBER  
DATE OF PURCHASE  
NAME OF RETAILER  
PART NUMBERS REQUIRED

### Guarantee

This product is guaranteed for **DOMESTIC USE ONLY** for a period of **1 YEAR** from the original certified date of purchase. During this period we have the right to: -

- a). Provide parts for the purchaser to effect repair.
- b). Repair the product, returned to our warehouse (at the purchaser's cost).

This guarantee does not cover wear and tear on upholstery or consumables.

This guarantee does not cover abuse, defects caused by storage or use outside those intended.

If you need to advise us of a defect with your product and in order for us to service any requirement for replacement parts or repairs, we may ask for proof of purchase. Failure to do so may result in any claim for replacement parts or repairs being refused.

This guarantee, (both given and implied) applies to the original purchaser only, is not transferable and will be invalidated if used outside of the above criteria.

This guarantee is valid only in the United Kingdom and Eire.

This does not affect your statutory rights as a consumer.

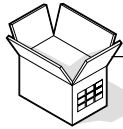

## **Before you Start**

---

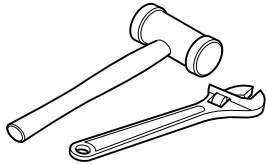

### **Tools**

*If required, most of our products are supplied with basic tools, which will enable you to successfully assemble your product. However, you may find it beneficial to have a soft-headed hammer and perhaps an adjustable spanner handy as this may help.*

### **Prepare the Work Area**

*It is important that you assemble your product in a clean, clear, uncluttered area. This will enable you to move around the product while you are fitting components and will reduce the possibility of injury during assembly.*

### **Work with a Friend**

*You may find it quicker, safer and easier to assemble this product with the help of a friend as some of the components may be large, heavy or awkward to handle alone.*

### **Open the Carton.**

*Carefully open the carton that contains your product, taking note of the warnings printed on the carton to ensure that the risk of injury is reduced. Be aware of sharp staples that may be used to fasten the flaps as these may cause injury. Be sure to open the carton the right way up, as this will be the easiest and safest way to remove all the components.*

### **Unpack the Components**

*Carefully unpack each component, checking against the parts list that you have all the necessary parts to complete the assembly of your product.*

*Please note that some of the parts may be pre-fitted to major components, so please check carefully before contacting our CUSTOMER SUPPORT team.*

*In any event, please do not return the product to your retailer before contacting us first.*



# Safety

*Before you undertake any programme of exercise that will increase cardiovascular activity please be sure to consult with your doctor. Frequent strenuous exercise should be approved by your doctor and proper use of your product is essential. Please read this manual carefully before commencing assembly of your product or starting to exercise.*

- \* Please keep all children away from exercise products when in use. Do not allow children to climb or play on them when they are not in use.*
- \* For your own safety, always ensure that there is at least 1 Metre of free space in all directions around your product while you are exercising.*
- \* Regularly check to see that all nuts, bolts and fittings are securely tightened. Periodically checking all moving parts for obvious signs of wear or damage.*
- \* Clean only with a damp cloth, do not use solvent cleaners. If you are in any doubt, do not use your product, but contact CUSTOMER SUPPORT by any of the means listed on the opposite page.*
- \* Before use, always ensure that your product is positioned on a solid, flat surface. If necessary, use a rubber mat underneath to reduce the possibility of slipping in use.*
- \* Always wear appropriate clothing and footwear such as training shoes when exercising. Do not wear loose clothing that could become caught or trapped during exercise.*

## Storage and Use

*Your product is intended for use in clean dry conditions. You should avoid storage in excessively cold or damp places as this may lead to corrosion and other related problems that are outside our control.*

## Weight Limit

*Your product is suitable for users weighing:  
220LBS / 15.7 Stones / 100 KG or less.*

## Conformity

*This product conforms to:  
(BS EN 957) - PARTS 1 and 6 Class (H) - HOME USE - Class (C).  
It is NOT suitable for therapeutic purposes.*



## **Exercising Information**

---

### **Beginning**

*How you begin to exercise will vary from person to person. If you have not exercised for a long period of time, have been inactive for a while, or are severely over weight you **MUST** start slowly, increasing your exercise time gradually, by perhaps only a few minutes for each session per week.*

*Combine a carefully structured nutritious diet with a simple but effective exercise routine and this can help make you feel better, look better and will almost certainly enable you to enjoy life more.*

### **Aerobic Fitness**

*Aerobic exercise is simply defined as any sustained activity that increases the supply of oxygen to your muscles via the blood pumped by your heart. With regular exercise, your cardiovascular system will become stronger and more efficient. Your recovery rate i.e. the time taken for your heart to reach its normal resting level, will also decrease.*

*Initially you may only be able to exercise for a few minutes each day. Do not hesitate to breathe through your mouth should you need more oxygen. Use the "talk test". If you cannot carry on a conversation while exercising, you are working too hard! However, aerobic fitness will be gradually built up with regular exercise, over the next six to eight weeks.*

*Do not be discouraged if it takes longer than this to begin to feel less lethargic, every one is different and some will achieve their targets quicker than others. Work at your own, comfortable pace and the results will come. The better your aerobic fitness the harder you will have to work to stay in your target zone.*



## Exercising Information

---

### Warm Up

*A successful exercise programme consists of three parts, Warm Up, Aerobic Exercise and Cool Down. Never start a training session without warming up. Never finish one without cooling down correctly. Perform between five and ten minutes of stretching before starting your workout to prevent muscle strains, pulls and cramps.*

### Aerobic Exercise Session

*Those new to exercise should exercise no more than every other day to start with.*

*As your fitness level increases, increase this to 2 in every 3 days.*

*When you are comfortable with your routine, exercise for 6 days per week. Always take at least one day off per week.*

### Exercising in your Target Zone

*To ensure that your heart is working in its exercise target zone, you need to be able to take your pulse. If you do not have a pulse monitor (either from the product you are using or a proprietary independent unit) you will need to locate the pulse in your carotid artery. This is situated in the side of the neck and can be felt by using the index and middle fingers. Simply count the number of beats you feel in 10 seconds and then multiply by six to get your pulse rate. This should be taken before you start to exercise for easy reference.*

*People who have a greater aerobic fitness, have a lower resting pulse level and will also be able to exercise with a higher pulse level.*

### Target Zone

*To determine your target zone, see the chart opposite. If you are new to exercise and by definition unfit, refer to the left column. If you exercise regularly and have good aerobic fitness, refer to the right column.*



## Exercising Information

### Target Zone (con't)

<b>USERS AGE</b>	<b>UNCONDITIONED TARGET ZONE - A</b>	<b>CONDITIONED TARGET ZONE - B</b>
(Years)	(Beats per Minute)	(Beats per Minute)
20-24	145 - 165	155 - 175
25-29	140 - 160	150 - 170
30-34	135 - 155	145 - 165
35-39	130 - 150	140 - 160
40-44	125 - 145	135 - 155
45-49	120 - 140	130 - 150
50-54	115 - 135	125 - 145
55-59	110 - 130	120 - 140
60 and over	105 - 125	115 - 135

### Cool Down

To decrease fatigue and muscle soreness, you should also cool down by walking at a slow relaxed pace for a minute or so, to allow your heart rate to return to normal.

### Warm Up and Cool Down Exercises

Hold each stretch for a minimum of ten seconds and then relax. Repeat each stretch two or three times. Do this before your Aerobic Exercise session and also after you have finished.

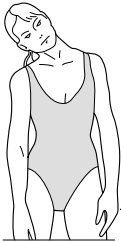

#### Head Roll

Rotate your head to the right for one count, feeling a slight pull on the left side of your neck. Next, rotate your head back for one count, stretching your chin. Then rotate your head to the left for one count, feeling a slight pull on the right side of your neck. Lastly, drop your head to your chest for one count. Repeat 2 to 3 times.



#### Toe Touch

Slowly bend forward from your waist, letting your back and shoulders relax as you lower your trunk. Gently stretch down as far as is comfortable and hold for 10 seconds.

## Exercising Information



### Shoulder Lift

Rotate and lift your right shoulder up towards your ear for one count. Relax then repeat for the left shoulder. Repeat 3 - 4 times.

### Calf / Achilles Stretch

Turn towards the wall and place both hands on it. Support yourself with one leg while the other is placed behind you with the sole flat on the floor. Bend the front leg and lean towards the wall, keeping the rear leg straight so that the calf and Achilles tendon are stretched hold for 5 seconds. Repeat with the other leg. Repeat 2 - 3 times.

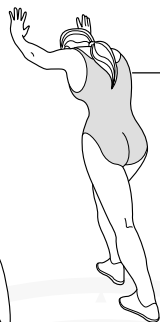

### Side Stretch

Open both arms to the side and gently lift them above your head. Reach your right arm as high as you can for one count, gently stretching the muscles of the stomach and lower back. Repeat the action with your left arm. Repeat 3 - 4 times.

### Inner Thigh Stretch

Sit on the floor and pull your legs toward your groin, the soles of your feet together. Hold your back straight and lean forward over your feet. Tighten the thigh muscles and hold for 5 seconds. Release and repeat 3 - 4 times.



### Hamstring Stretch

Sit on the floor with your right leg extended and place your left foot flat against the right inner thigh. Stretch forward toward the right foot and hold for 10 seconds. Relax and then repeat with the left leg extended. Repeat 2 - 3 times.





## Exercising Information

---

### Basic Aerobic Training Programme

For your basic Aerobic Exercise routine we suggest that you try the following. Remember, breathe correctly, exercise at your own pace and do not over-train as injury may result.

#### Week 1 & 2

Warm Up 5 - 10 Minutes  
Cool Down 5 Minutes

Exercise 4 minutes at 'A'  
Rest 1 minute  
Exercise 2 minutes at 'A'  
Exercise slowly 1 minute

---

#### Week 3 & 4

Warm Up 5 - 10 Minutes  
Cool Down 5 Minutes

Exercise 5 minutes at 'A'  
Rest 1 minute  
Exercise 3 minutes at 'A'  
Exercise slowly 2 minutes

---

#### Week 5 & 6

Warm Up 5 - 10 Minutes  
Cool Down 5 Minutes

Exercise 6 minutes at 'A'  
Rest 1 minute  
Exercise 4 minutes at 'A'  
Exercise slowly 3 minutes

---

#### Week 7 & 8

Warm Up 5 - 10 Minutes  
Cool Down 5 Minutes

Exercise 5 minutes at 'A'  
Exercise 3 minutes at 'B'  
Exercise 2 minutes at 'A'  
Exercise slowly 1 minute  
Exercise 4 minutes at 'A'  
Exercise slowly 3 minutes

---

#### Week 9 & beyond

Warm Up 5 - 10 Minutes  
Cool Down 5 Minutes

Exercise 5 minutes at 'A'  
Exercise 3 minutes at 'B'  
Exercise 2 minutes at 'A'  
Exercise slowly 1 minute  
Repeat entire cycle 2 or 3 times

---

*This is only a suggested programme and may not suit every individual's needs.*

# Assembly



## ACCESSORY FITMENT LIST

*These are all the accessories you will need to complete the assembly of your product.*

*The following accessories are supplied in a pack and should be checked before attempting assembly.*

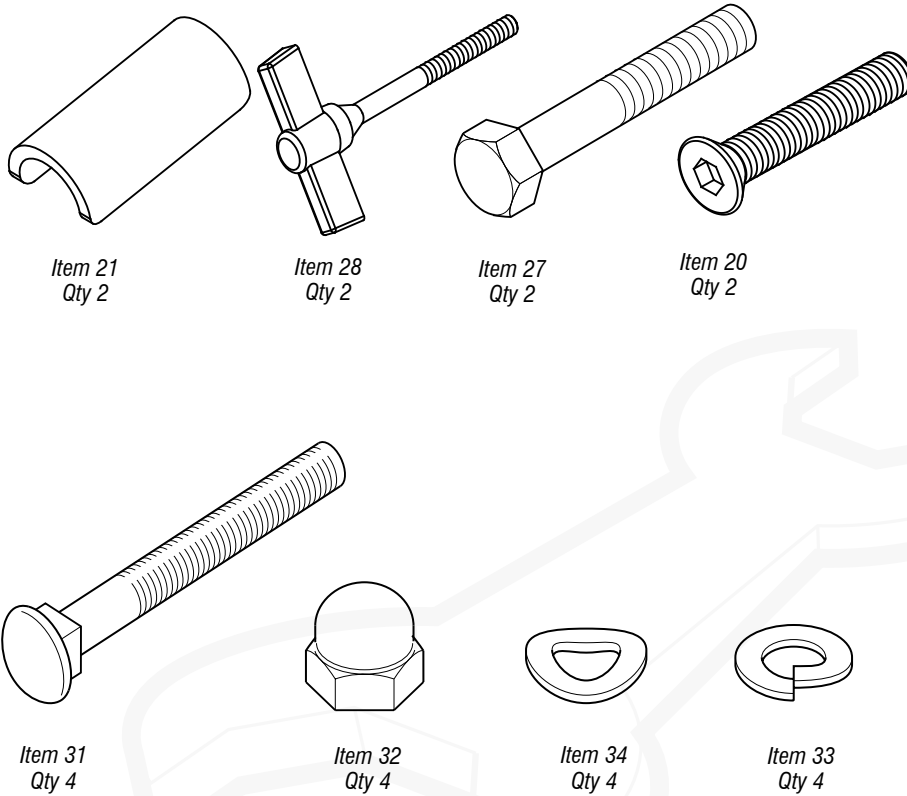

# Assembly



## D.I. Support

c/o Unit 8, Riparian Way,  
The Crossings, Cross Hills,  
West Yorkshire.  
BD20 7BW

Carefully unpack each component, checking against the parts list that you have all the necessary parts to complete the assembly of your product.

PLEASE NOTE that some of the parts may be pre-fitted to major components, so please check carefully before contacting our CUSTOMER SUPPORT team.

In any event, please do not return the product to your retailer before contacting us first.

Fax:- 01535 637722 or

E-mail:- [help@disupport.co.uk](mailto:help@disupport.co.uk)

**1**

Put the Base Frame (2) under the Handlebar Uprights (3R & 3L) and secure in place using 4 x M8 x 65mm Carriage Bolts (31), 4 x M8 Curve Washers (34), 4 x M8 Spring Washers (33), and 4 x M8 Nylon Dome Nuts (32).

Connect the Treadmill Main Frame (1) to the Assembled Uprights (3R & 3L) using 1 x M10 x 65mm Bolt (27) and 1 x Locking Knob (28) for each side making Sure the Locking Knob is below the M10 Bolt.

Connect both ends of the Computer Pickup Sensor (46) and Lower Computer Wire (24).

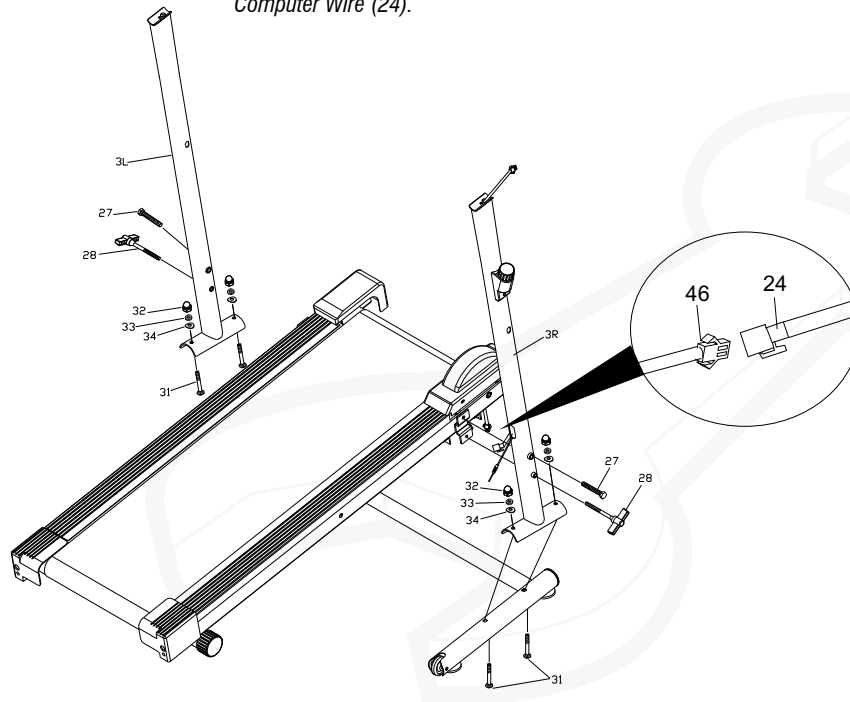

# Assembly

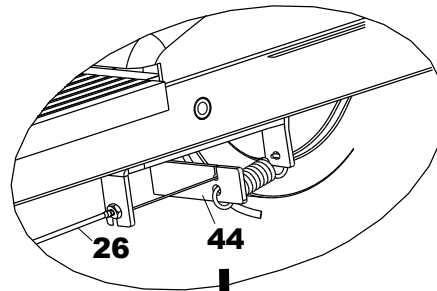
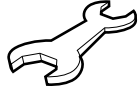

Turn the Tension Control Knob (26) fully anti-clockwise. Unscrew the nut on the end of the Tension Control Knob Cable (26) so it is loose on the cable. Hook the Cable end onto the Magnet Bracket (44) (as shown in FIG.C i).

Pull the outer Black Cable so that the Magnet Bracket (44) moves away from the Flywheel (5). Slot the end of the outer cable into the Fixed Bracket (as shown in FIG.C ii).

Refit the Nut removed in step (i) above ensuring that the Nut is tight. (FIG.C iii)

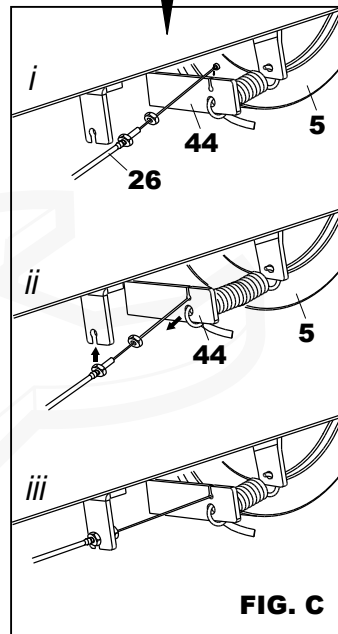

## Assembly



2 Attach the Handlebar (4) to the Handlebar Uprights (3R & 3L), and secure in place using 2 x M8 x 40mm Allen Bolts (20) and 2 x Covers (21). Connect the end of the Upper Computer Wire (25) and Lower Computer Wire (24). Connect the Computer (23) to the Upper Computer Wire (25) and the 2 x Hand Pulse Wires (51). Connect the hand pulse wires to the computer (23). Sandwich the two plastic halves of the Computer (23) around the Handlebar (4).

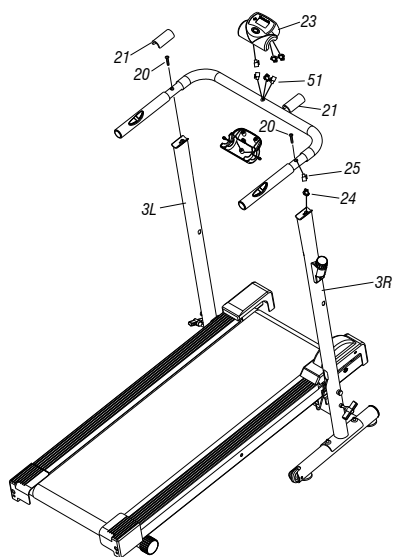

3 Your Treadmill can be folded up for easy storage or transportation. Simply remove Knobs (28) and lift the main frame (1) until the hole in the side of the Frame aligns with the hole in the side of the Treadmill. Lock the Frame in the position using Knobs (28). You will find the Treadmill easy to move by pulling the Handlebar towards your body and wheeling it on the castors (37).

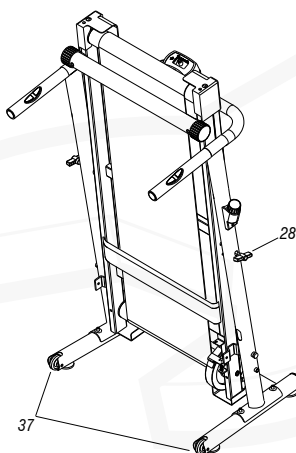

# Assembly



## ADJUSTING THE BELT TRACKING

When using the Treadmill for the first time you may find the Belt (8) moves to one side. This can be easily overcome using the Belt Adjustment Bolts located at the rear of the Base Frame.

If the Belt runs to the right you will need to adjust the Adjustment Bolt on the Right Rear Base Frame by turning it half a turn (Clockwise) using Tool (Supplied). Test the Belt for 1-2 minutes, if it still runs to the right then try another half turn. If after a further 1-2 minutes the Belt is still not running centrally do not tighten the right bolt again. Adjust the Adjustment Bolt on the Left Rear Base Frame one half a turn (Counter Clockwise) Now test it again for 1-2 minutes.

Reverse the Operation if the belt runs to the Left.

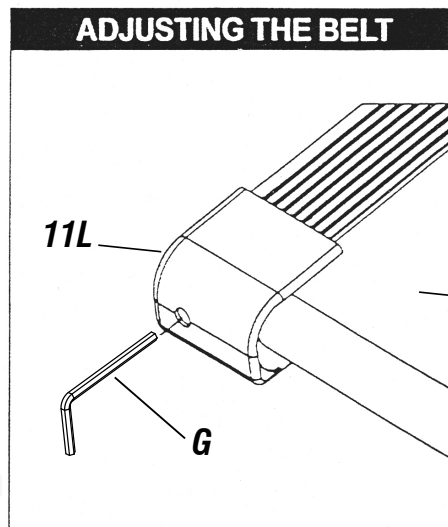

## TENSION

If the Belt is too loose tighten (Clockwise) both Adjustment Bolts one half a turn each. If it is still too loose, then turn (Clockwise) both Bolts one half a turn again.



## ***Exercise Notes***

---

*Use this space to record your own exercise routine results.*

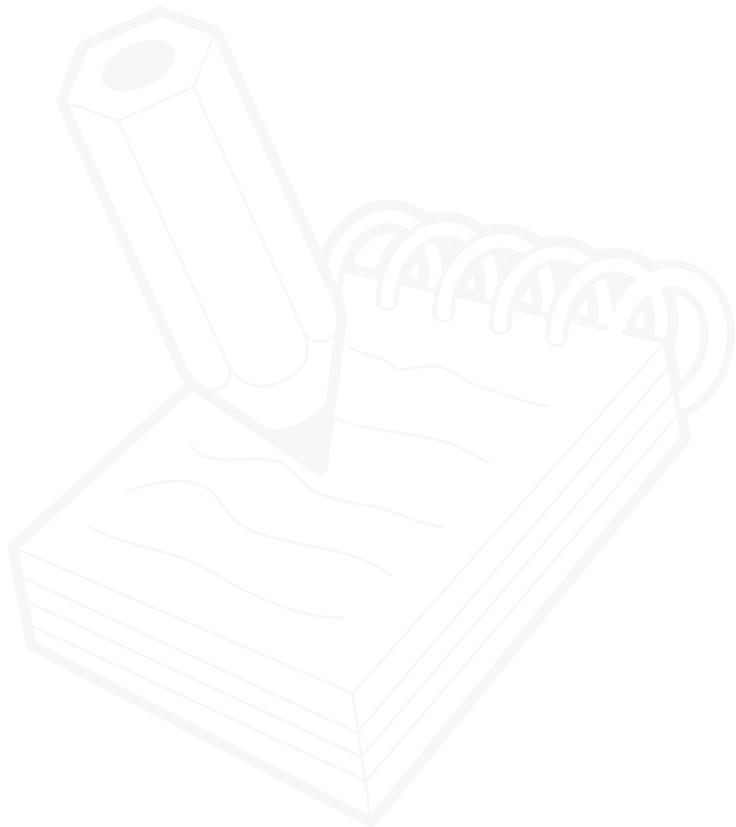

# Assembly

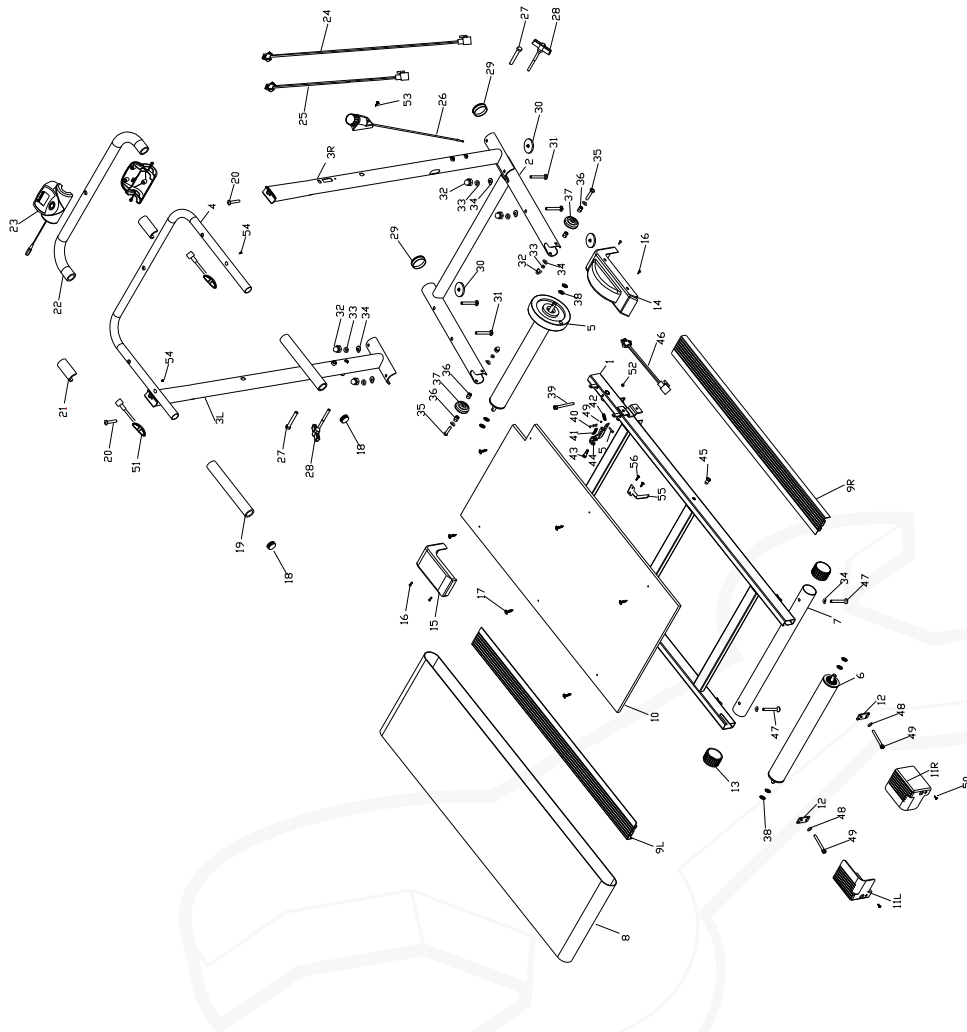

# Assembly



<b>PART No.</b>	<b>DESCRIPTION</b>	<b>QTY</b>			
1	MAIN FRAME	1	31	M8 x 65mm CARRIAGE BOLT	4
2	BASE FRAME	1	32	M8 NUT	6
3L	HANDLEBAR UPRIGHT L	1	33	M8 SPRING WASHER	6
3R	HANDLEBAR UPRIGHT R	1	34	M8 CURVE WASHER	10
4	HANDLEBAR	1	35	M8 x 60mm BOLT	2
5	FLYWHEEL	1	36	SPACER	2
6	REAR ROLLER	1	37	ROLLER WHEEL	2
7	REAR SUPPORT	1	38	FLAT WASHER	8
8	BELT	1	39	M6 x 60mm BOLT	4
9L	SIDE STEP COVER L	1	40	MAGNETIC	3
9R	SIDE STEP COVER R	1	41	MAGNETIC PLATE	1
10	TREADMILL DECK	1	42	MAGNETIC BRACKET SPRING	1
11L	REAR ROLLER GUARD L	1	43	M8 x 50mm BOLT	1
11R	REAR ROLLER GUARD R	1	44	MAGNETIC BRACKET COVER	1
12	ADJUSTMENT STOP PLATE	2	45	THREADED INSERT	1
13	FEET CAP	2	46	COMPUTER PICKUP SENSOR	1
14	FLYWHEEL COVER	1	47	M8 x 65mm BOLT	4
15	LEFT FRONT COVER	1	48	FLAT WASHER	2
16	SCREW	4	49	NUT	1
17	SCREW	6	50	M4 x 10mm SCREW	2
18	ROUND HANDLEBAR END CAP	2	51	HAND PULSE	2
19	HANDLEBAR GRIP 150mm	2	52	NYLON NUT	2
20	M8 x 40mm ALLEN BOLT	2	53	SCREW	2
21	COVER	1	54	SCREW	2
22	HANDLEBAR GRIP 940mm	1	55	BELT LEAD	2
23	COMPUTER	1	56	SCREW	4
24	LOWER COMPUTER WIRE	1	57	M6 x 40mm BOLT	1
25	UPPER COMPUTER WIRE	1			
26	TENSION	1			
27	M10 x 65mm HEX BOLT	2			
28	M8 x 80mm LOCKING KNOB	2			
29	ROUND END CAP	2			
30	BUMPER	4			



## Note

Some of the above accessories are pre-fitted to the master component. They may not be supplied separately

**PRO FITNESS**

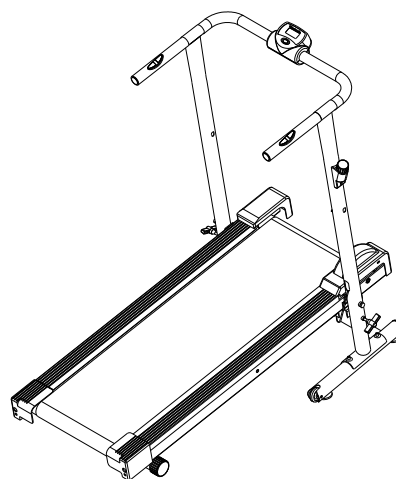

***D.I. Support***

*c/o Unit 8, Riparian Way,  
The Crossings, Cross Hills,  
West Yorkshire.  
BD20 7BW*



*Fax: 01535 637722*



*E-mail: [help@disupport.co.uk](mailto:help@disupport.co.uk)*

*Copyright BSCL 2007*

*Printed June / 2007*