

**PRO FITNESS**

923-7300(D)  
**ROWER 'N' GYM**





## **CONTENTS**

<b><i>Important Safety Information</i></b> .....	<b>1</b>
<b><i>Exploded View</i></b> .....	<b>2</b>
<b><i>Parts List</i></b> .....	<b>3</b>
<b><i>GYM N ROWER Parts checking list</i></b> .....	<b>4</b>
<b><i>Assembly Instructions</i></b> .....	<b>5</b>
<b><i>Folding For Storages</i></b> .....	<b>9</b>
<b><i>Exercise Guide</i></b> .....	<b>10</b>
<b><i>Exercise Instructions</i></b> .....	<b>11</b>
<b><i>Exercise Computer</i></b> .....	<b>13</b>
<b><i>Exercise Session</i></b> .....	<b>14</b>



## **Important Safety Information**

**Please keep this manual in a safe place for reference.**

1. It is important to read this entire manual before assembling and using the equipment. Safe and efficient use can only be achieved if the equipment is assembled, maintained and used properly. It is your responsibility to ensure that all users of the equipment are informed of all warnings and precautions.
2. Before starting any exercise program you should consult your doctor to determine if you have any physical or health conditions that could create a risk to your health and safety, or prevent you from using the equipment properly. Your doctor's advice is essential if you are taking medication that affects your heart rate, blood pressure or cholesterol level.
3. Be aware of your body's signals. Incorrect or excessive exercise can damage your health. Stop exercising if you experience any of the following symptoms: Pain, tightness in your chest, irregular heartbeat, extreme shortness of breath, feeling light headed, dizzy or nauseous. If you do experience any of these conditions you should consult your doctor before continuing with your exercise program.
4. Keep children and pets away from the equipment. The equipment is designed for adult use only.
5. Use the equipment on a solid, flat level surface with a protective cover for your floor or carpet. For safety, the equipment should have at least 0.5 meter of free space all around it.
6. Before using the equipment, check the nuts and bolts are securely tightened.
7. The safety level of the equipment can only be maintained if it is regularly examined for damage and/or wear and tear.
8. Always use the equipment as indicated. If you find any defective components whilst assembling or checking the equipment, or if you hear any unusual noise coming from the equipment during use, stop. Do not use the equipment until the problem has been rectified.
9. Wear suitable clothing whilst using the equipment. Avoid wearing loose clothing which may get caught in the equipment or that may restrict or prevent movement.
10. The equipment has been tested and certified to EN957 under class H.C. Suitable for domestic, home use only. Maximum weight of user, 100kg. Breaking is speed independent.
11. The equipment is not suitable for therapeutic use.
12. Care must be taken when lifting or moving the equipment so as not to injure your back. Always use proper lifting techniques and/or use assistance.
13. All moveable accessories (eg. Pedal, saddle.etc.) do require weekly maintenance. Check them before use each and every time. If anything broken or loose, please fix them immediately.

# EXPLODED-VIEW ASSEMBLY DRAWING

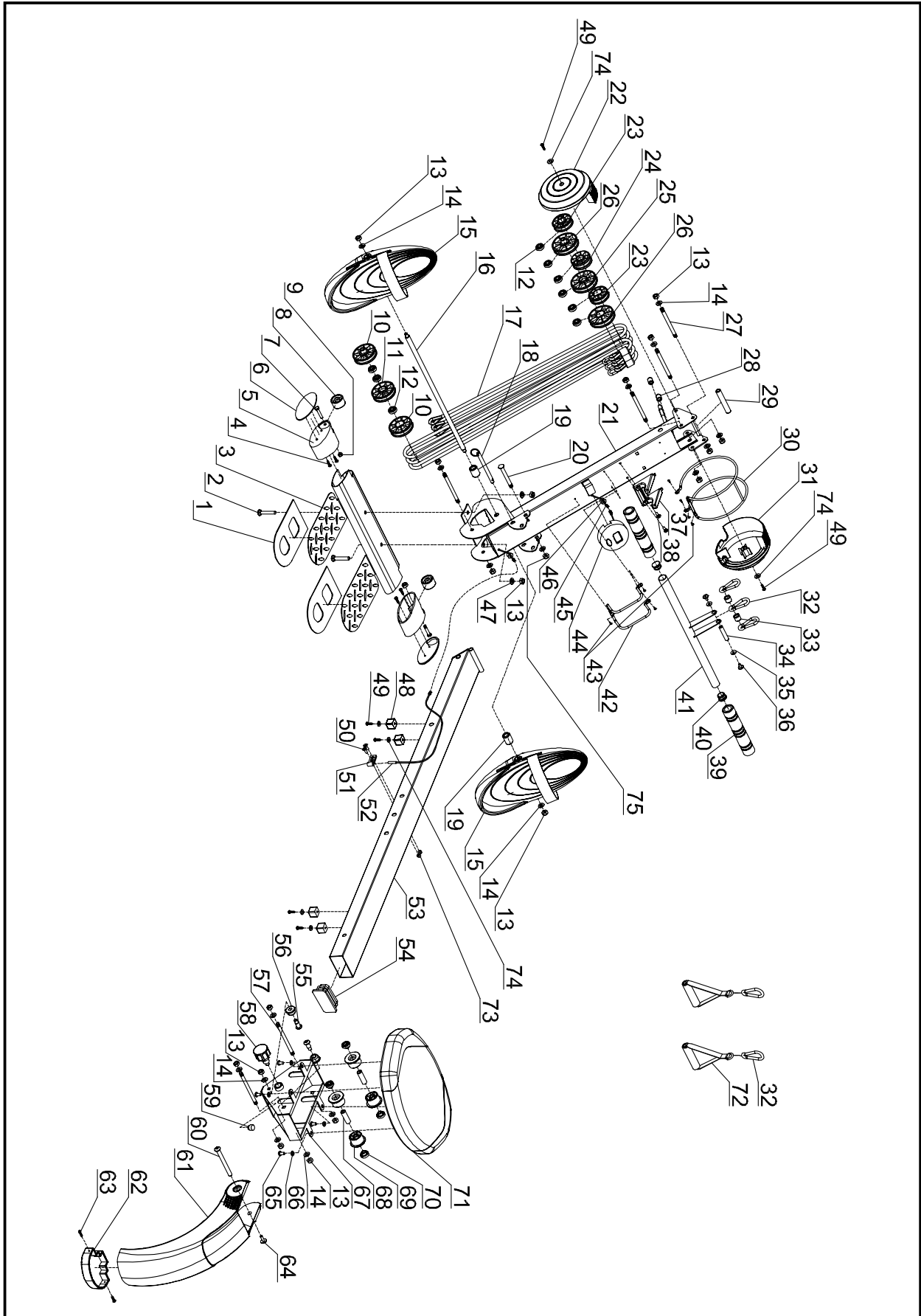

<b>PART NO.</b>	<b>DESCRIPTION</b>	<b>Q'TY</b>	<b>PART NO.</b>	<b>DESCRIPTION</b>	<b>Q'TY</b>
1.	Rubber pad	2	39.	Foam grip	2
2.	Bolt (M8*47)	2	40.	End cap	2
3.	Front stabilizer	1	41.	Handlebar	1
4.	Screw (ST4.2*10)	4	42.	Computer protector	1
5.	End cap	2	43.	Screw (ST2.9*8)	7
6.	End cap cover	2	44.	Computer	1
7.	Bolt (M6*40)	2	45.	Upper computer wire	1
8.	Transport wheel	2	46.	Wire bracket	1
9.	Lock nut (M6)	2	47.	Curved washer (Φ8)	2
10.	Pulley (φ 63*29.25)	2	48.	Stopper	4
11.	Pulley (φ 63*20.5)	1	49.	Screw (ST4.2*13)	6
12.	Bearing	9	50.	Screw (M5*12)	2
13.	Lock nut (M8)	18	51.	Sensor	1
14.	Washer	17	52.	Lower computer wire	1
15.	Pedal	2	53.	Roller tube	1
16.	Axle for pedal	1	54.	End cap	1
17.	Weave belt	3	55.	Bolt (Φ 10*14.5*M8)	2
18.	Pin	1	56.	Bushing	2
19.	Bushing	2	57.	Bolt (φ 8*115)	2
20.	Bolt (M8*95)	1	58.	Adjustment knob	1
21.	Main frame	1	59.	Magnet	1
22.	Chain cover (L)	1	60.	Bolt (Φ 9.5*94.5*M6)	1
23.	Pulley (φ 53*29.25)	2	61.	Rear stabilizer	1
24.	Pulley (φ 53*20.5)	1	62.	Slip resistance mat	1
25.	Pulley (φ 73*20.5)	1	63.	Screw (ST2.9*16)	2
26.	Pulley (φ 73*29.25)	2	64.	Screw (M6*10)	1
27.	Axle	4	65.	Screw (M6*15)	4
28.	Bushing	2	66.	Flat washer	4
29.	Bushing	1	67.	Seat bracket	1
30.	Chain cover framework	1	68.	Bushing	2
31.	Chain cover (R)	1	69.	Sear wheel	4
32.	Hook	5	70.	Bearing	4
33.	Bushing	2	71.	Seat	1
34.	Axle	1	72.	Pull sets	1
35.	Washer	2	73.	Lock nut	2
36.	Screw (M5*10)	2	74.	Flat washer	6
37.	Handlebar bracket	1	75.	Lock nut	1
38.	Screw (M5*15)	2			

# GYM N ROWER PARTS CHEKcing LIST

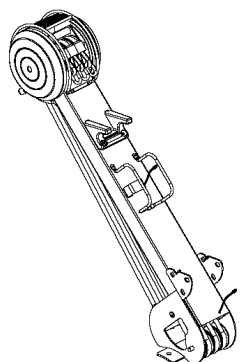

**MAIN FRAME\*1**

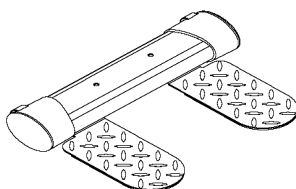

**FRONT STABILIZER\*1**

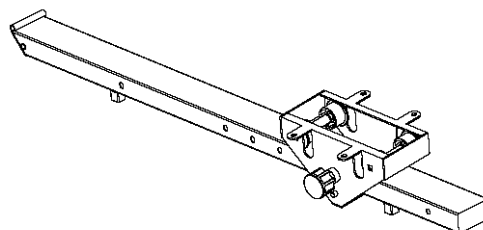

**ROLLER FRAME\*1**

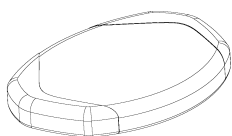

**SEAT\*1**

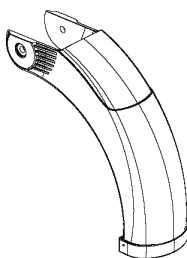

**REAR STABILIZER\*1**

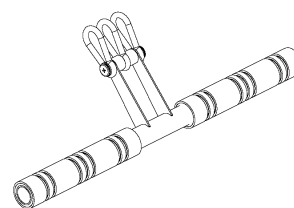

**HANDLE BAR SET\*1**

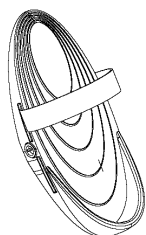

**PEDAL\*2**

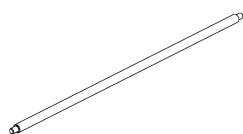

**AXLE FOR PEDAL  
(Φ12\*440)\*1**

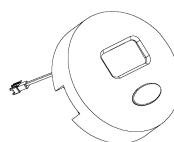

**COMPUTER\*1**



**PULL HANDLE SET\*1**



**HOOK\*2**

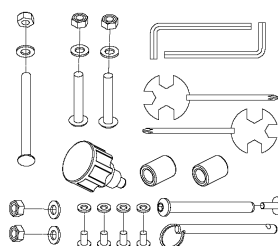

**TOOL PACK\*1**

**\*\*Hardware might have already pre-assembled onto the components**

# ASSEMBLY INSTRUCTIONS

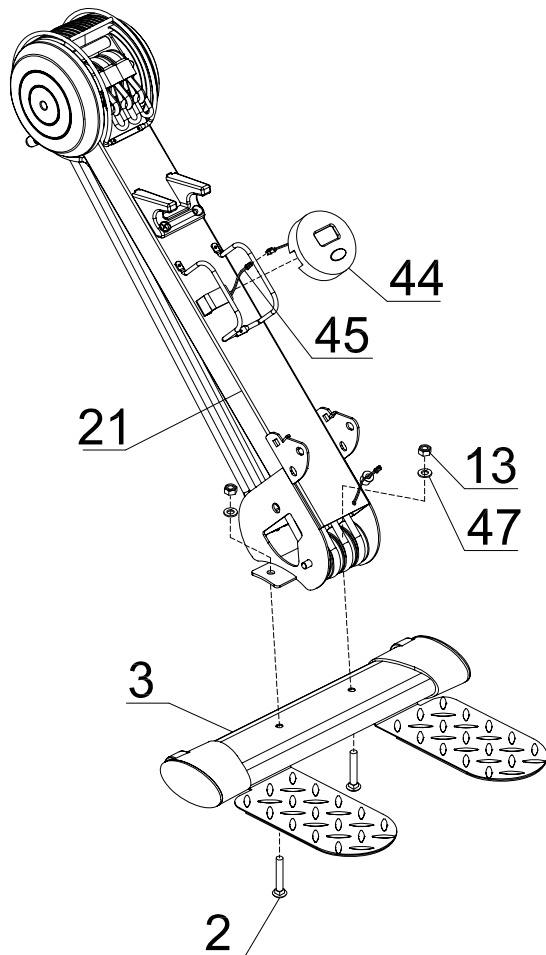

## STEP 1

Connect the front stabilizer (3) to the main frame (21) by use the bolt M8\*47 (2), Curved washer  $\varphi$  8 (47) and lock nut M8 (13).

Connect the computer (44) wire to the upper computer wire (45), then fix the computer on the computer bracket of main frame (21).

## STEP 2

Connect the seat (71) to the seat bracket (67) by use the Screw M6\*15 (65) and flat washer (66) then lock Adjustment knob (58).

**REMARK:** Adjust the Seat to the position using Adjustment knob (58)

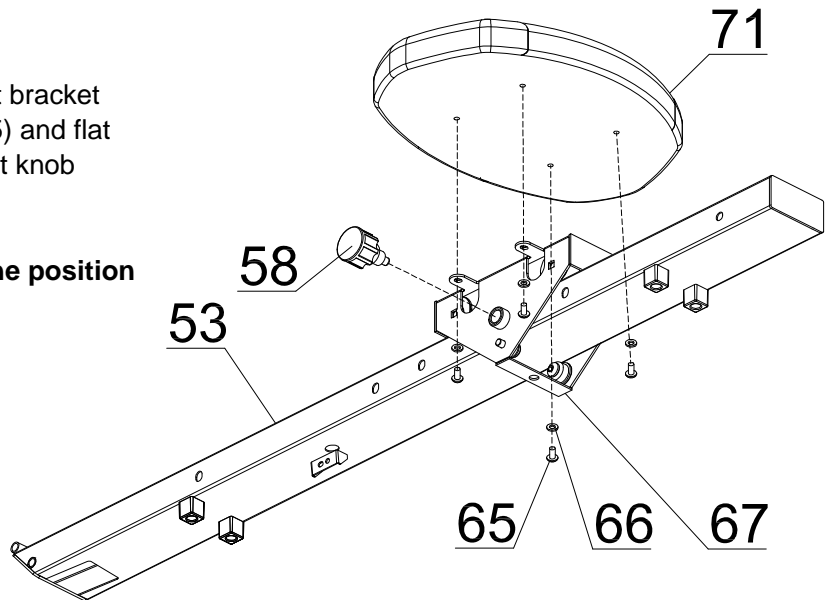
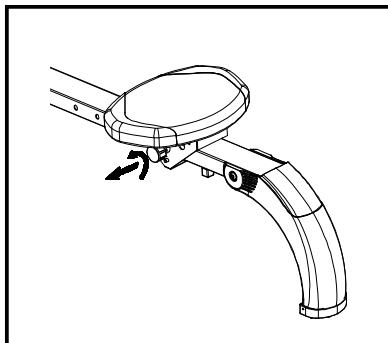

### **STEP 3**

Connect the rear stabilizer (61) to the roller tube (53) by use the bolt (60) and screw (M6\*10) (64).

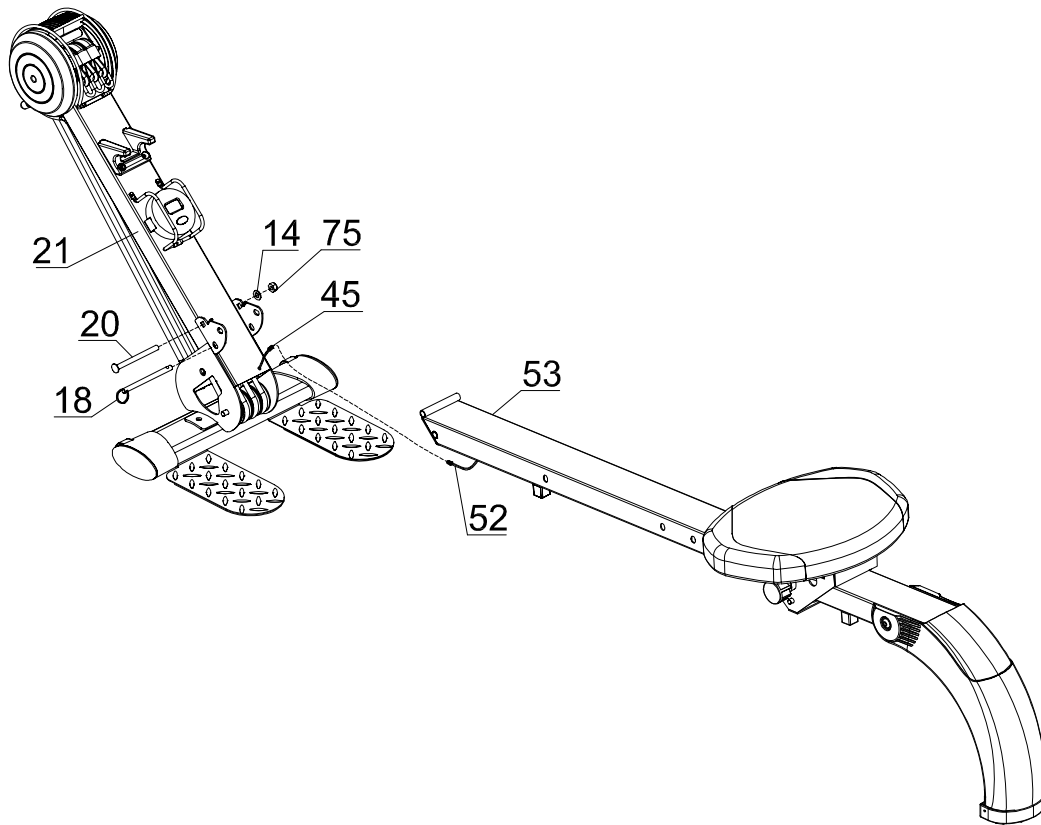
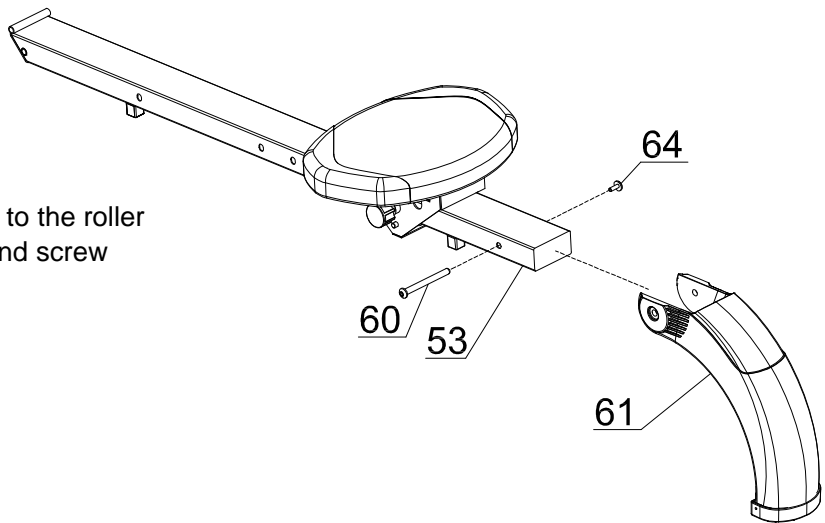

### **STEP 4**

1. Connect the upper computer wire (45) to the lower computer wire (52),
2. Put the roller tube (53) into main frame (21) and then assemble by use bolt M8\*95 (20), Washer (14) and lock nut M8 (75).
3. Insert the pin (18).

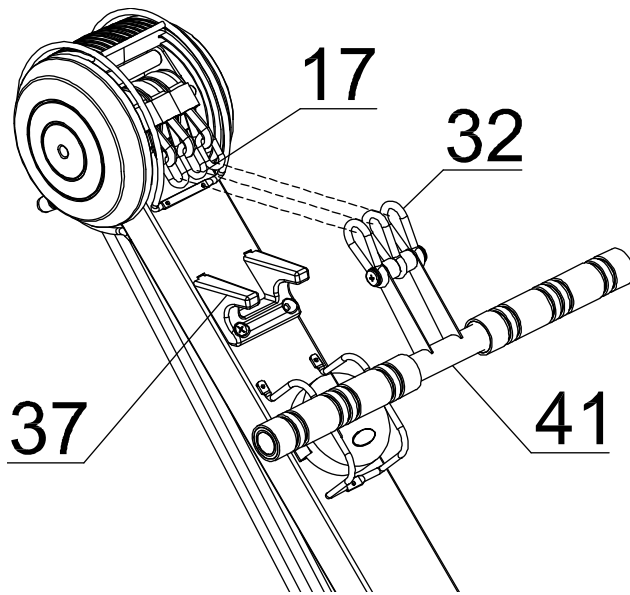

**STEP 5**

Buckle the handlebar hook (32) with weave belt hook (17) then put on handlebar bracket (37).

**ATTENTION:**

There are 3 levels of tension.

Tension level varies on the number of belts, 1 belt for least resistance, 3 belts for highest resistance.

**ATTENTION:**

Please change the weave belts (17), a consuming parts when it is damaged or the diameter shrinks. The defect photo and changing procedure are as below :

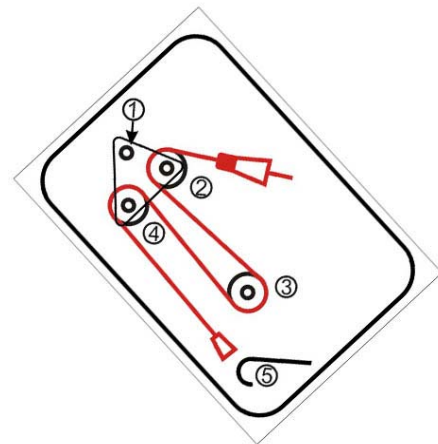
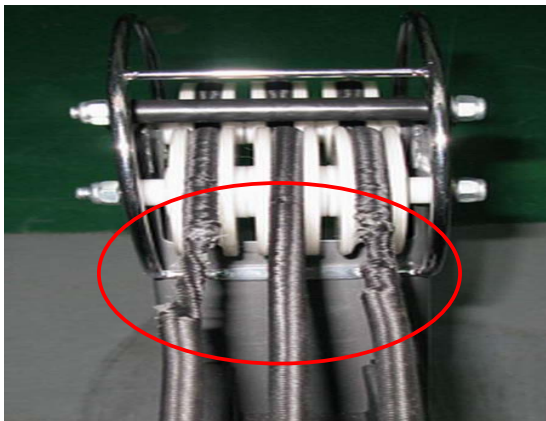

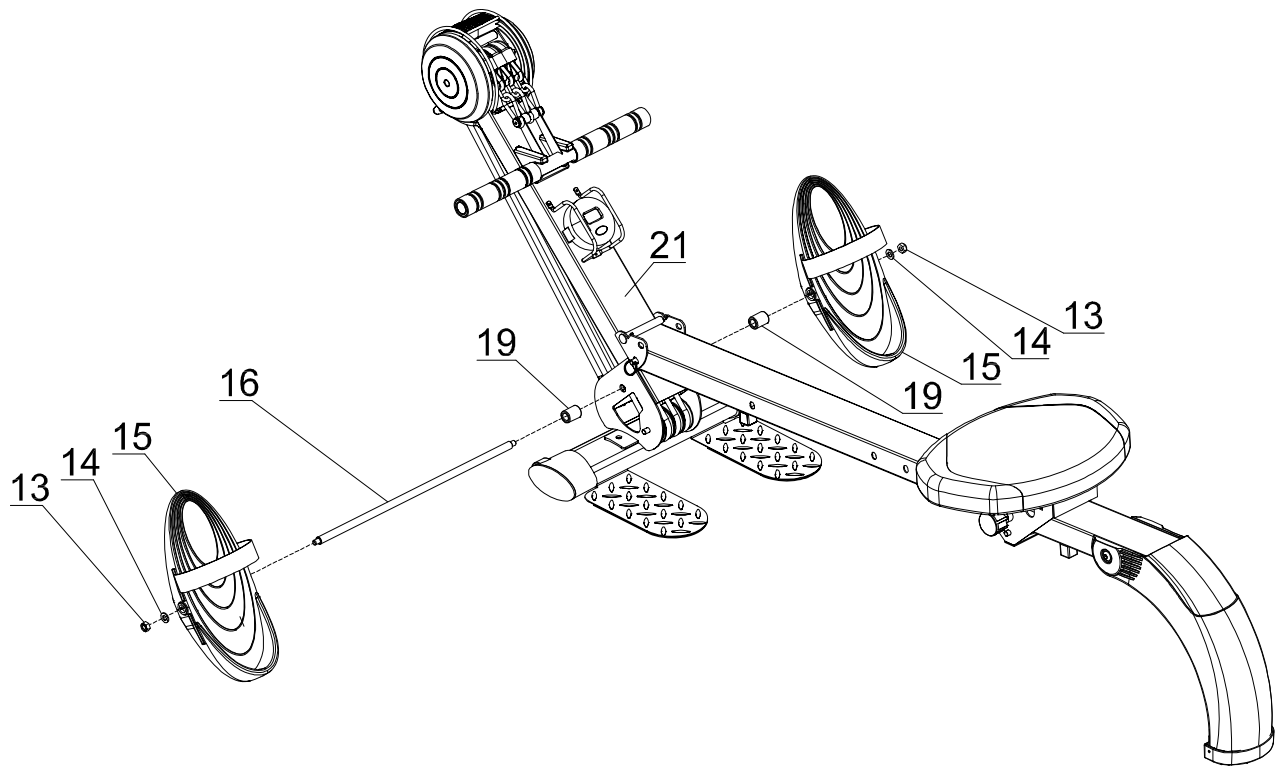

**STEP 6**

Assembly Pedal (15), Bushing (19) and (Axle for Pedal) (16) to the Main frame (21) by use lock nut M8 (13) and Washer (14).

## FOLDING FOR STORAGE

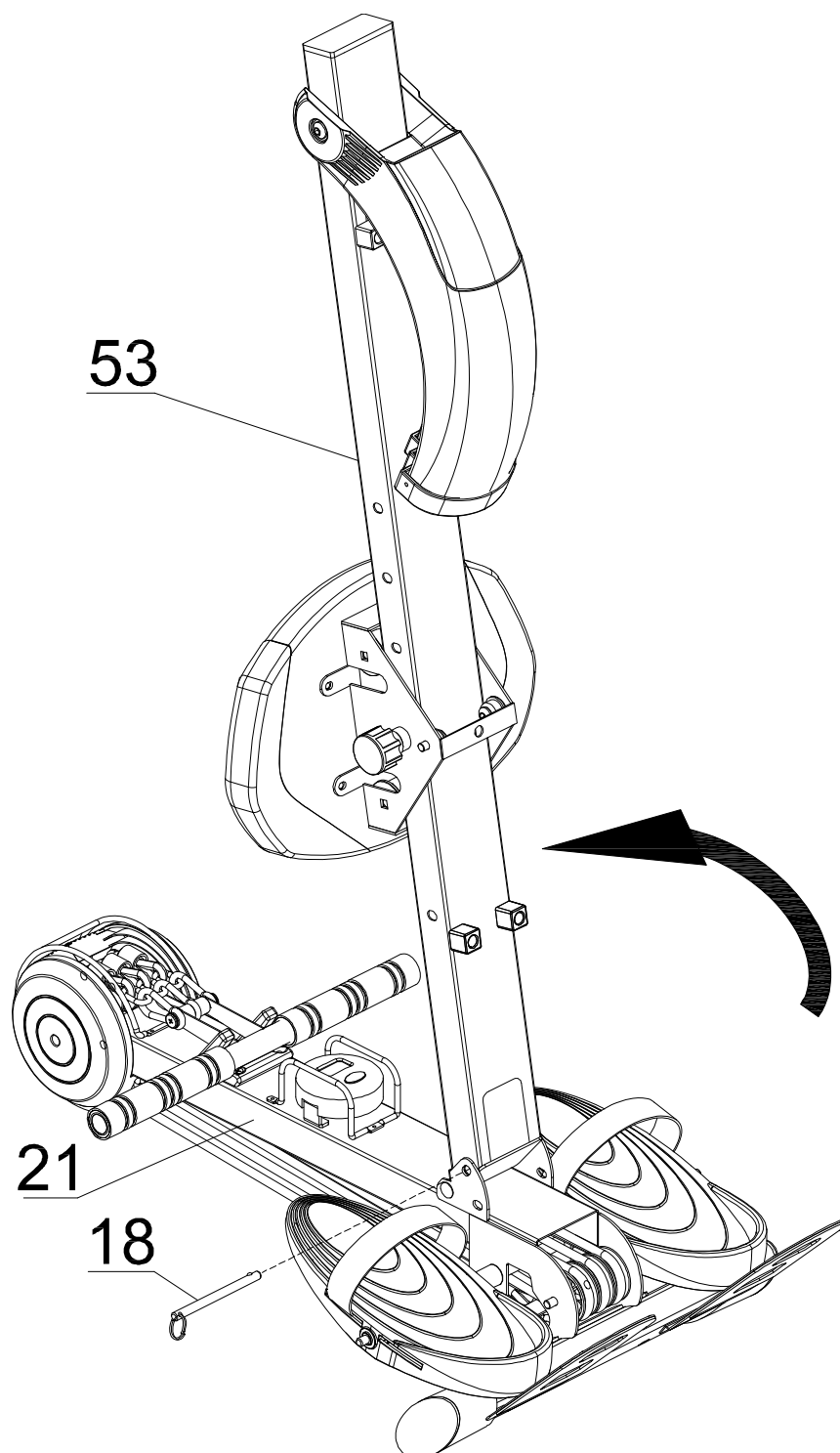

Pull the pin (18) out of the main frame (21), then turn roller tube (53) anticlockwise, insert pin (18) to the hold.

# **EXERCISE GUIDE**

Rowing is an extremely effective form of exercise. It strengthens the heart and improves circulation as well as exercising all the major muscle groups; the back, waist, arms, shoulders, hips and legs.

## **The Basic Rowing Stroke**

- 1) Sit on the saddle and fasten your feet to the pedals using the Velcro straps. Then take hold of the rowing bar.
- 2) Take up the starting position, leaning forward with your arms straight and knees bent as shown in (Fig 1).
- 3) Push yourself backwards, straightening your back and legs at the same time (Fig 2).
- 4) Continue this movement until you are leaning slightly backwards, during this stage you should bring your arms out of the side. (Fig 3). Then return to stage 2 and repeat. See attached.

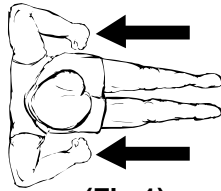

**(Fig.1)**

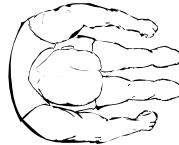

**(Fig.2)**

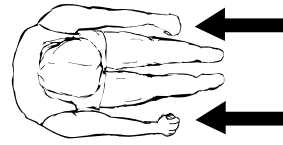

**(Fig.3)**

## **Training Time**

Rowing is a strenuous form of exercise, because of this it is best to start with a short, easy exercise programmed and build up to longer and harder workouts. Start rowing for about 5 minutes and as you progress, increase the length of your work out to match your improving level of fitness. You should eventually be capable of rowing for 15-20 minutes, but do not try to achieve this too quickly.

Try to train on alternate days, 3 times a week. This gives your body time to recover between workouts.

## **Alternate Rowing Styles.**

### **Arms Only Rowing**

This exercise will tone muscles in your arms, shoulders, back and stomach. Sit as shown in Fig 4 with your legs straight, lean forward and grasp the handles. In a gradual and controlled manner lean back to just past the up right position continuing to pull the handles towards your chest. Return to the starting position and repeat. See attached.

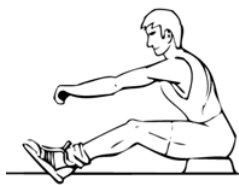

**(Fig.4)**

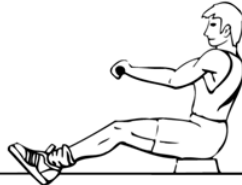

**(Fig.5)**

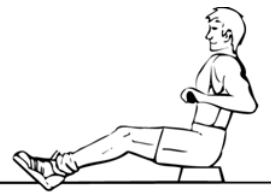

**(Fig.6)**

### **Legs Only Rowing**

This exercise will help tone muscles in your legs and back. With your back straight and arms out stretched, bend your legs until you are grasping the rowing arm handles in the starting position, Fig 7. Use your legs to push your body back whilst keeping your arms and back straight.



**(Fig.7)**



**(Fig.8)**



**(Fig.9)**

# **EXERCISE INSTRUCTIONS**

Using your **GYM N ROWER** will provide you with several benefits. It will improve your physical fitness, tone your muscles and, in conjunction with a calorie-controlled diet, help you lose weight.

## **1. The Warm-Up Phase**

This stage helps get the blood flowing around the body and the muscles working properly. It will also reduce the risk of cramp and muscle injury. It is advisable to do a few stretching exercises as shown below. Each stretch should be held for approximately 30 seconds. Do not force or jerk your muscles into a stretch - if it hurts, **STOP**.

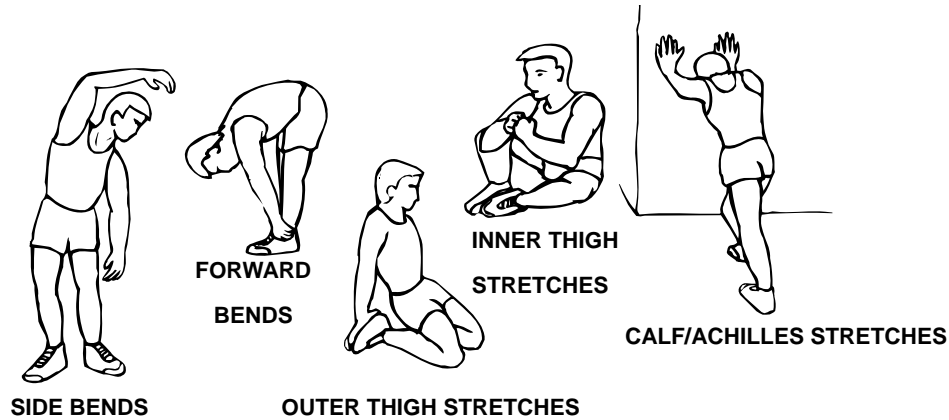

## **2. The Exercise Phase**

This is the stage where you put the effort in. After regular use, the muscles in your legs will become more flexible. Work at your own pace, but be sure to maintain a steady tempo throughout. The rate of work should be sufficient to raise your heartbeat into the target zone shown on the graph below.

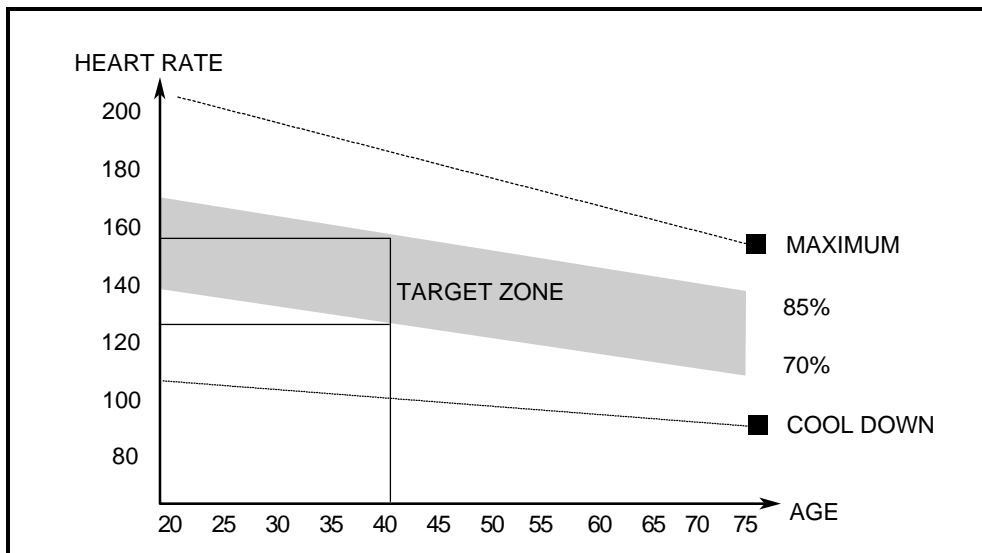

This stage should last for a minimum of 12 minutes though most people start at about 15-20 minutes.

## **3. Cooling-Down Phase**

This stage is to let your cardio-vascular system and muscles wind down. This is a repeat of the warm-up phase. First, reduce your tempo and continue at this slower pace for approximately 5 minutes before you get off your Exercise Bike. The stretching exercises should now be repeated, again remembering not to force or jerk your muscles into the stretch.

As you get fitter you may need to train longer and harder. It is advisable to train at least three times a week, and if possible to space your workouts evenly throughout the week.

## **MUSCLE TONING**

To tone muscle while on your ROWING MACHINE you will need to have the resistance set quite high. This will put more strain on our leg muscles and may mean you cannot train for as long as you would like. If you are also trying to improve your fitness you need to alter your training program. You should train as normal during the warm up and cool down phases, but towards the end of the exercise phase you should increase resistance making your legs work harder. You will have to reduce your speed to keep your heart rate in the target zone.

## **WEIGHT LOSS**

The important factor here is the amount of effort you put in. The harder and longer you work the more calories you will burn. This is effectively the same as if you were training to improve your fitness, the difference being the goal.

## **MAINTENANCE**

1. Before using the ROWING MACHINE, always make sure all bolts/nuts are fully tightened.
2. A spent battery is hazardous waste – please dispose of it correctly and do not throw it in the trash.
3. When eventually you want to scrap the machine, you should remove the batteries from the computer and dispose of them separately as hazardous waste.

# **EXERCISE COMPUTER**

## **Appearance**

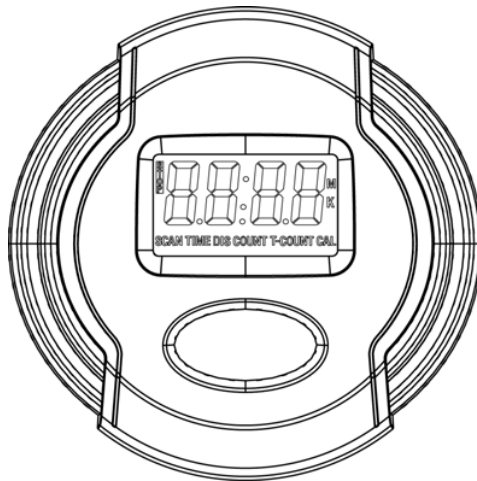

## **Functions and Operations**

### **1. Batteries Installation**

Please install 1 piece of AAA 1.5V batteries in the battery case on the back of monitor.  
(Whenever Batteries are removed, all the functions values will be reset to zero.)

### **2. Auto On/Off**

While the user starts to do exercise, the Display will show out the workout value automatically. Once stop exercising over 256 sec, the Display will turn off. But the workout value of count/ total count /cal will be hold. While user starts exercise again, workout value of count/ total count /cal will accumulate continuously.

\*\* Press the button for 2 seconds, all the function value except T-COUNT will be reset to zero.

### **3. Auto Scan**

After the monitor is power on or press the button, the LCD will display all functions values from Time-Count- T-Count – Cal. Each value will be held for 6 seconds.

### **4. Count**

Display the step from 0 to 9999.

### **5. Total Count:**

Display the total steps from 0 to 9999.

### **6. Time**

Display the workout time from 00:00 to 99:59. User also can press the button to display the workout time value.

### **7. Calories**

Display the calories consumption during training from 0.0 to 9999. User also can press the button to display the calories consumption value.

## **EXERCISE SESSION**

### **EXERCISE 1    LEG N THIGH BURNER ROW**

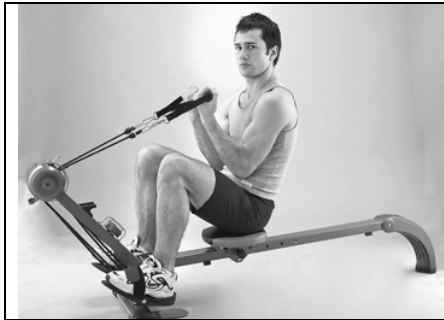

Sit facing the front of the Gym N Rower. Position the seat close to the mainframe. Have your knees bent and your feet firmly in the footrest. Now, grip the handsets and, keeping your elbows tucked at your sides, inhale and extend your legs straight, pushing your body backward. Hold a moment, and then exhale as you return to first position.



Repeat seven to 10 times, rest, and then do another set. This will work your thighs and lower leg muscles, as well as your shoulders and back. To increase the tension, hook up another resistance strap. But please don't overdo it; if you get tired, do less reps.

### **EXERCISE 2    FRONT DELTOID PULL**



For this exercise sit with your back to the mainframe. Grasp the pulley handle and bring it up to your shoulder. Grasp the roller bar with your other hand for support.

Now, as you inhale, extend your arm out in front of you. Hold this pose a moment, and then exhale as you retract your arm to first position

Repeat seven to 10 times, depending on your present level of strength; then do another set. When you've completed one arm, work the other.



This movement will give your front deltoids a good workout.

### EXERCISE 3 TRICEP BURNER

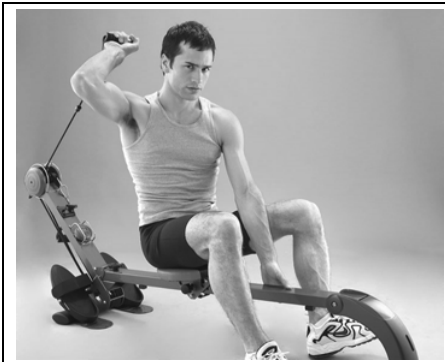

Sitting in the same position as the above exercise, grip one handle holding it near the back of your head like this. Your other hand can hold onto the roller tube for support. Inhale and extend your arm up over your head. Hold it there a moment... and exhale as you return your arm to first position.

Repeat this action several times and do a couple of reps before working the other arm



This exercise focuses primarily on the tricep muscles, but it also gives your upper back a good workout.

### EXERCISE 4 UPPER BODY PRESS



Again, sit with your back to the mainframe. Now, take the handles in each hand like this. Your legs should be bent and your feet flat on the floor for good support. Take a breath in and as you exhale extend your arms out in front of you. Hold a moment as you tense your chest muscles.

Now, breathe in as you slowly return your arms to first position. Do several reps and two set of this exercise.



This is a wonderful overall exercise that has all the benefits of the bench press. Your whole upper body is brought into play when doing this motion.

## EXERCISE 5 THE POWER PULL

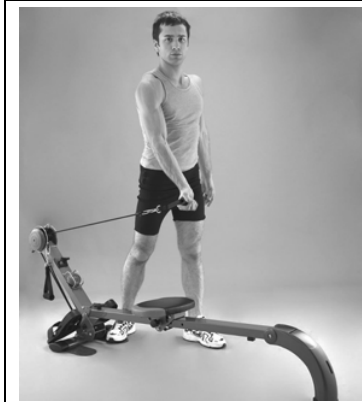
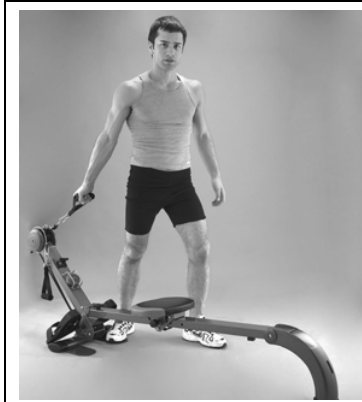

To do the Power Pull, stand to one side of your Gym N Rower like this, with your right foot on the front stabilizer footplate. (This is the position if you're working your right arm. Reverse it when working the left arm.) Now, take the handle in your right hand, like this. Keep your arm straight but not rigid. Now, pull the strap as if you were doing an underhand stroke in tennis. Hold it a moment; then go back. To work your waistline, twist your upper body as you pull the strap. Time this rhythmic movement with your breathing as you do several repetitions.

This motion is excellent for your shoulders and upper arms, as well as your waistline.

Remember to do both sides of your body.

## EXERCISE 6 POWER PULLBACK

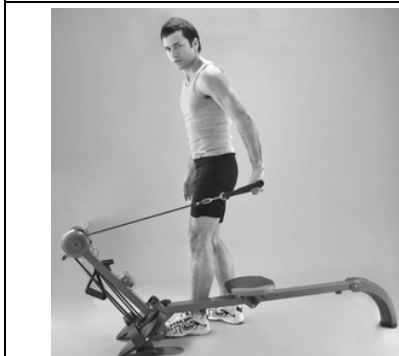
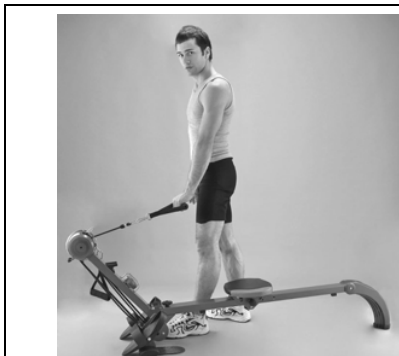

Stand on one side of the Gym N Rower facing the mainframe. Keep your legs approximately shoulder width apart and have one leg on the front stabilizer footplate. To work the left arm, grasp the handle with your left hand and hold it in this ready position. Keep your arm firm and close to your body. Now, inhale and pull the strap backward and behind you. Hold this position a moment, then exhale and return your arm to first position.

Do several reps and two sets, before switching sides.

This exercise will work your shoulders, upper arms, and back muscles.

## **EXERCISE 7 REAR DELTOID/TRICEP PULLBACK**



For the Rear Deltoid / Tricep Pullback exercise place your right knee comfortably on the padded seat rest. Your left hand can be supported on your left knee, or on the head of the mainframe.

Now, take hold of the pulley handle with your right hand and bring it up to this position. Keep your elbow bent and close to your torso. Take a breath in and pull your arm back. Hold a moment before exhaling and returning to first position.

Positioning your body in this way places localized tension on your arms thereby giving your shoulder and upper arm and lats a more intensive workout. Remember to do both sides of your body.

## **EXERCISE 8 GYM N ROWER POWER TWIST**



Facing the mainframe, sit on the seat rest and secure your feet properly in the footrests.

Grip one of the pulley handles and bring it up to your shoulder area. Now, start twisting your upper body from the waist, first to the left then to the right. Breathe rhythmically as you do so.

Be careful not to twist beyond your limit to avoid injury.

Do several repetitions and do the exercise again with your other hand.

This will work your whole upper body and take inches off your waistline.

## EXERCISE 9 HALF SQUATS



For this exercise stand straight facing the mainframe; your legs should be on either side of the roller tube and placed firmly on the front stabilizer foot plates.

Now, take the handles, one in each hand, and bring them up around your chin or upper chest area. Keep your elbows in. Take a couple of breaths to ready yourself. Now, as you inhale, bend your knees into a half squat. Hold a moment, then exhale as you stand up straight again.

Do several sets and two reps.

This exercise will tone up your thighs and buns, as well as other muscles in your legs and lower back.



## EXERCISE 10 POWER ARM ROTATION



Stand adjacent to the mainframe, like you did in the power pull exercise. To work the right arm, your stance will be like this – left knee slightly bent and placed firmly on the front stabilizer footplate.

Now, take the handset with your right hand and hold it in this position; your elbow is bent and close to your side. Keeping your arm bent, inhale as you rotate your arm pulling the cord across your chest. Hold a moment, then exhale and return to first position.

Repeat several times and do two sets, before working your left arm.

This works your entire arm, waist and upper body.



## EXERCISE 11 SHOULDER POWER LIFT

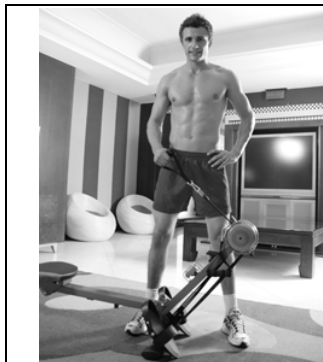

Stand on one side of the Gym N Rower and grip the handle with your right hand. Your right foot should be on the footplate. Now exhale and raise your arm bringing it to shoulder level.... Hold it a moment then return to first position as you exhale.

Do seven to 10 reps and two sets before working the left arm.

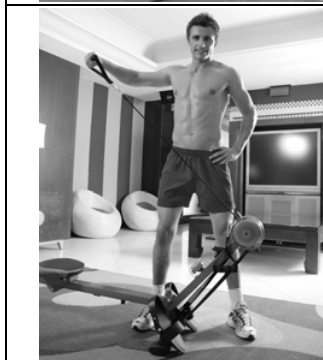

This exercise is great for your shoulder muscles.

## EXERCISE 12 BURNER ROW



For this variation on the Burner Row, you'll need to connect the handlebar to the resistance cords. Sit comfortably facing the mainframe and secure your feet on the footrests.

Take hold of the handlebar. Now breath in and as you do so extend your legs straight and pull the handlebar to your chest at the same time. Hold this position a moment; then exhale bending your legs and extending your arms to return to first position.



This rowing action is great for the whole body

For an effective workout, we recommend you do two sets of seven to 10 repetitions.

## EXERCISE 13 LOWER BACK POWER



For this exercise you will again use the handlebar. Now, sitting in the same position as the last exercise, place the handlebar across the inner elbows like this. Your feet should be placed securely in the footrests and your knees bent at about 90 degrees. Staying in this posture, inhale and arch your back, pulling the cords as you do so, to about a 45-degree angle. Hold a moment before exhaling and returning to first position. Do several repetitions and two sets. This is a great exercise to increase strength and muscle tone in your back. Remember not to strain your waist by leaning too far back. Always go easy at first; you can increase the intensity of the movement after more practice.

## EXERCISE 14 STANDING BICEP CURLS

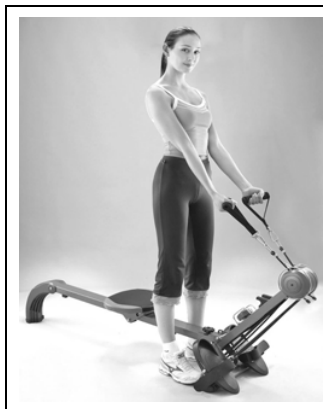

For the standing bicep curls, face the mainframe and straddle the roller bar. Grasp the handsets firmly, one in each hand. Keep your body upright and your elbows close to your sides.

Now, inhale and flex your arms pulling the straps up to your chest. Hold this position a moment, then exhale as you easily extend your arms returning to first position. That's a full bicep curl. You may also alternate each arm in this exercise (i.e., one arm extends as the other flexes).

Do seven to 10 repetitions and two sets.

Remember to focus on your breathing and on the muscle parts you are working during all exercises to get the most out of them.

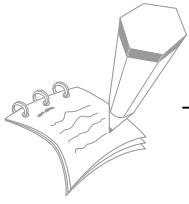

## EXERCISE NOTES

---

*Use this space to record your own exercise routine results.*

# PRO FITNESS



**Dimensions (L\*W\*H)**                    1850 x 435 x 650 mm

**Batteries**                                    1 x AAA

**Class Rating**                                HC

**Maximum User Weight**                100KG

**Please note that the specifications are subject to change without notice.**

**Retailer:**                                    ARG

**Retailer address: 489-499 Avebury Boulevard  
Saxon Gate West  
Central Milton Keynes Bucks,  
MK9 2NW**